

Application Circuit Example

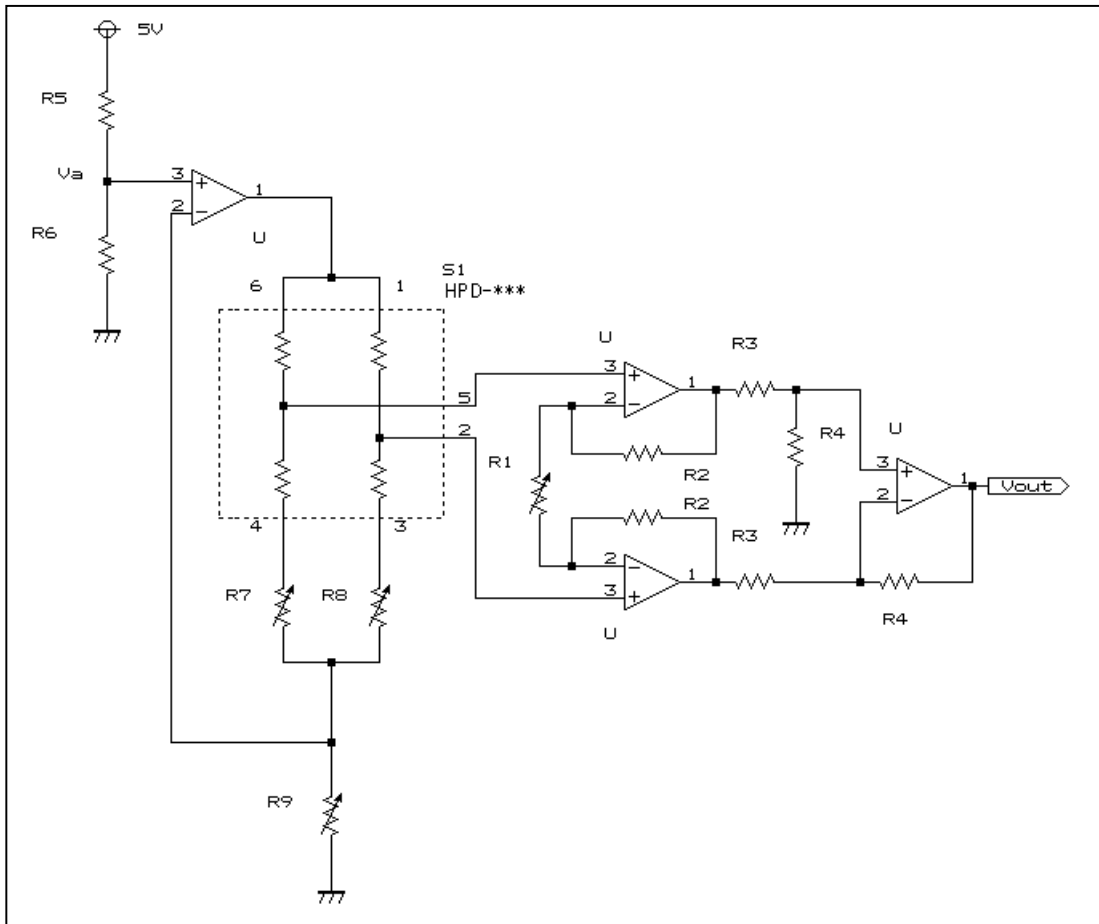

■ Amplifier Circuit

The output voltage of the pressure sensor (HPD Series) is 60 to 90 mV (span voltage). This is approximately 1.5 to 2.25 mV/kPa, resulting in an extremely small voltage when measuring low pressures.

Therefore, to ensure reliable circuit operation, we recommend using a differential amplifier circuit like the one below to amplify the output.

We recommend adjusting the offset.

For your reference, the amplified output calculation formula for this circuit is shown below.

$$V_{out} = V_{in} \cdot \frac{2R_2 + R_1}{R_1} \cdot \frac{R_4}{R_3}$$

The gain can be adjusted with R1 (or R3).

Here, Vout is the amplified output value, and Vin is the sensor element output value.

Constant Current Drive

We recommend driving the sensor with a constant current of 1mA. The setting can be adjusted with R9.

$$I_{drv} = V_a / R_9$$

Offset Adjustment

We recommend adjusting the offset voltage at 0kPa.

Adjustment can be made using R7 or R8.

※Note: Ensure the sensor output is received with high impedance.