



Double Sided (Silver / Copper) Polymer Through Hole Board

Features

- Significant cost reduction is possible by replacing copper plating through-hole PWB with polymer through-hole PWB.
- High density circuit design is widely available.
- Double sided surface mount PWB is available by using polymer through-hole PWB.
- Highly reliable PWB is realized by using polymer through-holes on paper phenolic board.

Construction

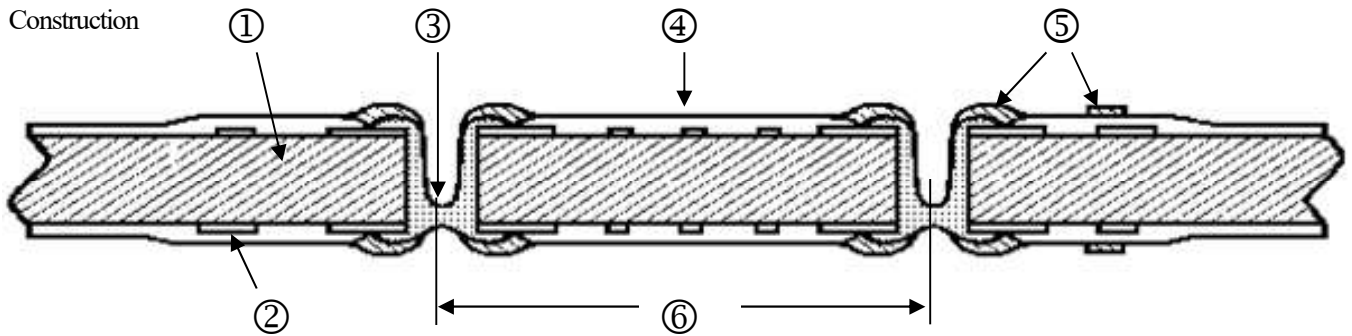

No.	Name	No.	Name
①	Base	④	Solder Resist
②	Copper Foil	⑤	Covercoat & Marking
③	Through-hole	⑥	Through-hole Pitch

(mm)

Design Requirement

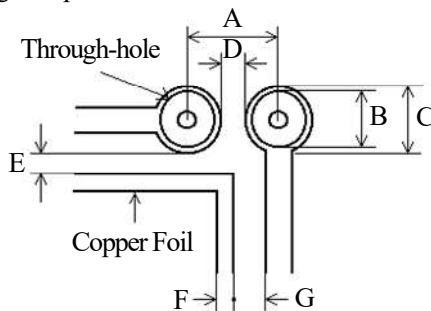

Through-hole Pitch:A	C	D	E	F	G
1.00	0.80	0.20	0.25	0.20	0.20
1.25	1.00	0.25	0.25	0.20	0.20
1.50	1.20	0.30	0.30	0.20	0.20
1.75	1.40	0.35	0.40	0.20	0.20
2.00	1.50	0.50	0.50	0.20	0.20
2.50	2.00	0.50	0.50	0.20	0.20

Specification

Item	Specification		Condition
	AgTh	CuTh	
Material of Base	FR-1, CEM-3		
Through-hole	Conductive Resin		Copper paste through-hole pitch: Min. 1.25mm
	Silver Paste	Copper Paste	
Ambient Temperature	-30~+100°C		
Through-hole Resistance	100mΩ/hole	100mΩ/hole	
Rated Current	300mA/hole	300mA/hole	
Max. Operation Voltage	50V (20V)	100V	Different electric potential Voltage (Applied less than 1.25mm pitch)
Load Life	200mΩ/hole	200mΩ/hole	70°C 1000Hr
Humidity Load Life	200mΩ/hole	200mΩ/hole	40°C 90~95%RH 1000Hr
High Temperature	200mΩ/hole	200mΩ/hole	100°C 1000Hr
Humidity	200mΩ/hole	200mΩ/hole	40°C 90~95%RH 1000Hr
Solder Dipping	200mΩ/hole	200mΩ/hole	260°C 5sec.
Reflow	200mΩ/hole	200mΩ/hole	240°C 3sec.
Migration	200mΩ/hole	200mΩ/hole	40°C 90~95%RH 1000Hr
Oil Dipping	200mΩ/hole	200mΩ/hole	260°C 10sec. 100Cycle
Heat Cycle	200mΩ/hole	200mΩ/hole	-40°C→100°C 30min 100Cycle



Double Sided (Silver / Copper) Polymer Through Hole Board

□ Characteristic (Reference Data)

- ▣ Ag Th : Ag Paste (1.5mm pitch, FR-1, t=1.6mm)
- ▣ Cu Th : Copper Paste (1.5mm pitch, FR-1, t=1.6mm)

