

Product specification

Pressure sensor: HPM-30GA-B24-2

-Table of contents-

- 1. Application -3-
- 2. Rating -3-
- 3. External dimensions and terminal arrangement -5-
- 4. Block Diagram -6-
- 5. Reliability test -7-
- 6. Notes -8-

1. Application

This specification applies to piezoresistive pressure sensor HPM-30GA-B24-2.

2. Rating

2-1. Absolute Maximum Ratings

item	Rating			Unit	Remarks
	MIN	TYP	MAX		
Storage temperature range	-40		85	°C	Do not freeze
Operating temperature limit	-30		85	°C	Do not freeze
Operating humidity range	0		90	%RH	No condensation
Supply Voltage	-0.3		6.0	V	
Applied pressure	-90		100	kPa	

※Do not use outside the absolute maximum rating range.

2-2. Use conditions

item	Rating			Unit	Remarks
	MIN	TYP	MAX		
Operating pressure range	0		31.25	kPa	
Operating supply voltage range	4.75	5	5.25	V	Ratiometric
Pressure medium	Non-corrosive Gas				
Pressure type	Gauge pressure				

2-3. Electrical characteristics (VDD=5V, T=25°C)

item	Rating			Unit	Remarks
	MIN	TYP	MAX		
Output form	DC				
Output accuracy	0.5+(a × P【kPa】)			V	0kPa = 0.5V 31.25kPa = 3V P=Applied Pressure【kPa】 a=2.5/31.25 【V/kPa】 T=-10~60°C
Output accuracy	-2		2	%FS	P=0~31.25kPa ※1 T=-10~60°C
Pressure linearity	-0.7		0.7	%FS	
Pressure hysteresis	-0.7		0.7	%FS	
Insulation resistance	20	-	-	MΩ	DC500V 1min between Terminal-Port
Withstanding voltage	-	-	1	mA	AC1kV 1min between Terminal-Port
Current consumption	-	-	2	mA	

※1 : Output span voltage 【FS】 Output of pressure P, temperature T(P,T)

$$\text{Output span voltage 【FS】} = V(31.25, 25) - V(0, 25)$$

The capacitive load connected to VOUT should be 0.01uF or less.

Output sink current and output source current of VOUT are 1 mA or less.

3. External dimensions and terminal arrangement

■ External dimensions [Unit: mm]

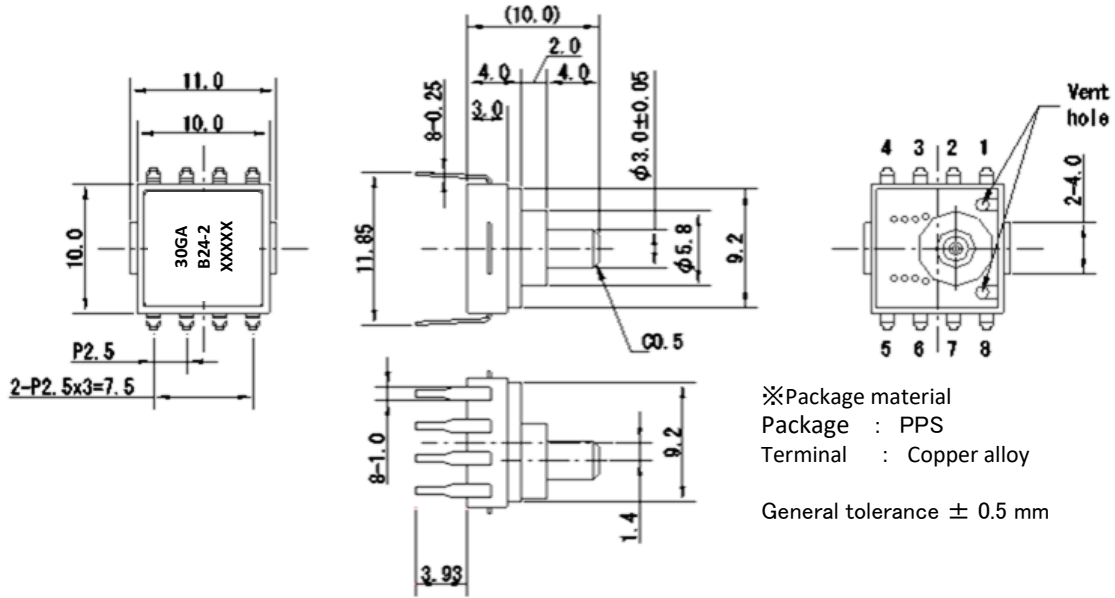

■ Board hole machining drawing

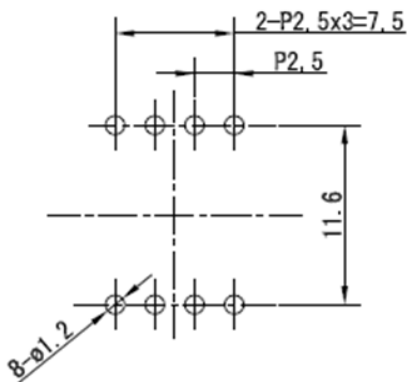

■ Terminal sequence

No	Terminal name	function
1	GND	Power supply GND terminal
2	VDD	Power supply input terminal
3	VO	Output signal terminal ※1
4	NC	Please use it unconnected
5	NC	
6	NC	
7	NC	
8	NC	

※ This shape guarantees the mounting quality
 Since there is not it, please check in advance
 at your company Thank you for your use.

※1 Refer to the "4. Block Diagram" section
 for connection method

※ Please be careful of miswiring
 If reverse voltage is applied, there is a danger of failure.

4. Block Diagram

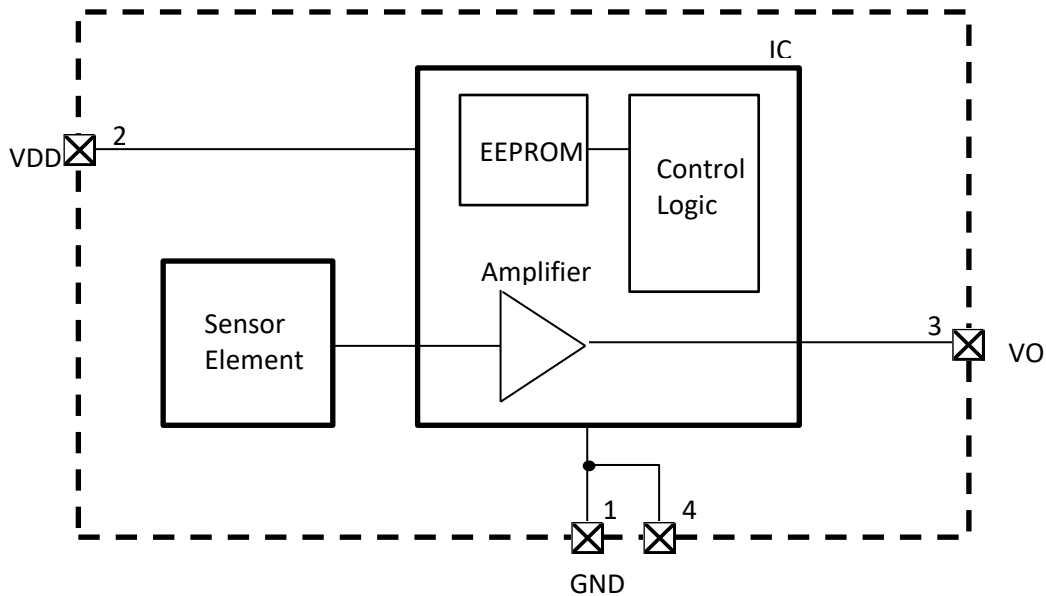

■ Connection example

VO is analog output terminal of DC voltage.

By A/D-converting output voltage from VO terminal, pressure value applied to pressure sensor can be taken into MCU.

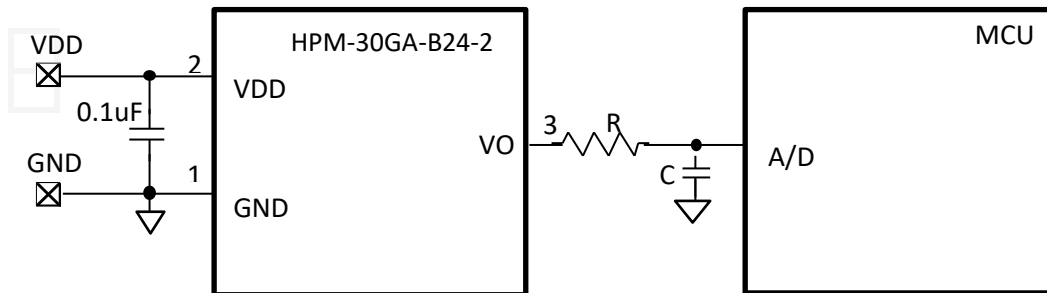

- *1 The capacitive load C that can be connected to the VO terminal is MAX 0.01uF.
- *2 A short circuit in the VO terminal will destroy the module. Please be careful about short circuit.
- *3 It is recommended to add R (100Ω) as short-circuit protection for the VO terminal.

5. Reliability test

Test items	Conditions
High temperature storage test	Leave it at 85 °C for 300 hr Output change amount after 4 hr or more out at normal temperature and humidity $\pm 3\%$ FS or less
Cold storage test	Leave it at -40 °C for 300 hr Output change amount after 4 hr or more out at normal temperature and humidity $\pm 3\%$ FS or less
Moisture resistance test	Temperature 40°C, humidity 90% RH, leave for 300 hours Output change amount after 4 hr or more out at normal temperature and humidity $\pm 3\%$ FS or less
Heat cycle test	100 cycles of temperature -40 °C (0.5 hr) \Leftrightarrow 85 °C (0.5 hr) Output change amount after 4 hr or more out at normal temperature and humidity $\pm 3\%$ FS or less
Pressure cycle test	Room temperature, Pressure 0kPa \Leftrightarrow 31.25kPa Cycle time 4 s (Duty 1: 1), 100,000 cycles Output change before and after test $\pm 3\%$ FS or less
Overpressure test	Maintain it at 100 kPa for 2 minutes and check that it will not leak Output change before and after test $\pm 3\%$ FS or less

6. Notes

- Please use within the absolute maximum rating stated in 2-1.
There is fear of damage and the breakdown when used outside the range of absolute maximum ratings.
- This product is not constructed as drip-proof. When it is sprayed with water, etc., or dew drops are produced, there is possibility of breakdown. Also, do not freeze pressure media, otherwise there is possibility of diaphragm breakdown.
- Please do not drop this product from high site. Do not apply strong impact. Otherwise, there is possibility of breakdown, failure.
- In case foreign object enters in pressure inlet valve, atmospheric air inlet valve, there is possibility of leakage or degradation of performance.
- Please do not apply static electricity reverse voltage to this product.
Otherwise, electronic components might break down or fail.
Please give special care for antistatic measures fully, when handling this product.
- If this product touches corrosive gas (organic solvent, sulfurous acid gas, hydrogen sulfide gas, etc.), it may have bad influence on performance.
- This sensor is intended to be used for general electrical equipment.
For any other uses falling into the following category, please contact to our company in advance.
Any uses in applications demanding extremely-high reliability such that failure or malfunction of medical equipment, safety device, aviation and space instrument, nuclear control equipment, combustion control apparatus, etc. is normally feared to cause serious damage to human life, body, property, etc., regardless direct or indirect.