



Management No. KRH2512079

## Product Specification

Article Name : Humidity Sensor

---

Model Name : HSU-08F9C1A-D

---

Date : February 9, 2023

---

**Hokuriku Electric Industry Co., Ltd.**

**Sensor & Piezo Division**

Model Name	Management No.	Page
HSU-08F9C1A-D	KRH2512079	2
<ol style="list-style-type: none"><li>01. Application</li><li>02. Type Name Designation</li><li>03. Outline and Dimensions</li><li>04. Absolute Maximum Ratings</li><li>05. Recommended Line Voltage Range</li><li>06. Measuring Circuit</li><li>07. Electrical Characteristic</li><li>08. Standard Reliability Test</li><li>09. Microcomputer connection and recommended circuit</li><li>10. Lot Number</li><li>11. Notes for Use</li><li>12. Others</li><li>13. Humidity Detection Output Characteristics (for Reference)</li></ol>		
<b>HOKURIKU ELECTRIC INDUSTRY CO., LTD.</b>		

Model Name	Management No.	Page
HSU-08F9C1A-D	KRH2512079	3

### 01. Application

This specifications shall be applied to the relative humidity sensor unit 「HSU-08F9C1A-D」.

### 02. Type Name Designation

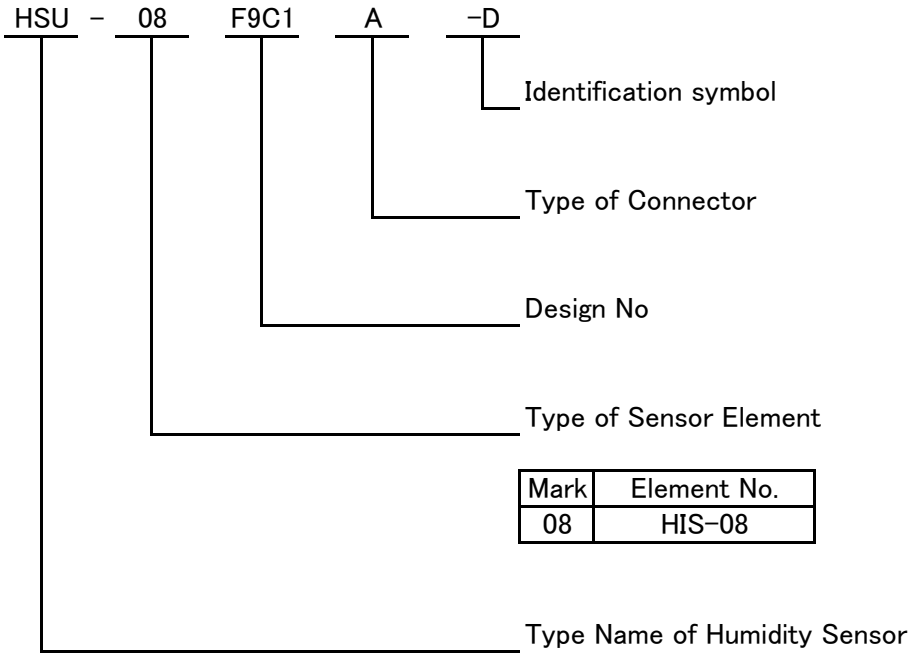

Model Name	Management No.	Page
HSU-08F9C1A-D	KRH2512079	4

### 03. Outline and Dimensions

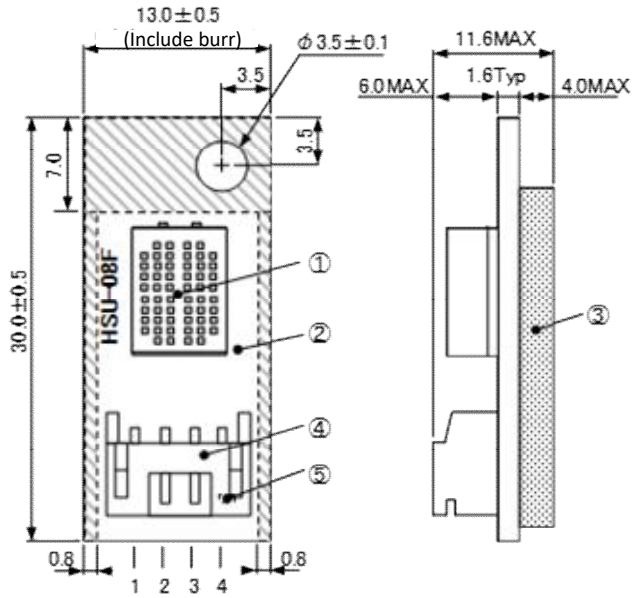

Unit : mm

Use Pb free solder (Sn-3.0Ag-0.5Cu)

\* Slash part is space for attachment.  
(No parts and wiring patterns)

#### Connector Pin Arrangement

Pin No.	Name	Mark
1	Power Source Terminal	Vcc
2	Output Terminal	Vout
3	Ground Terminal and Thermistor Terminal 1	GND
		TH1
4	Thermistor Terminal 2	TH2

#### Parts Component

Parts No.	Name	Material and Specification
①	Humidity Sensor	HIS-08 Manufactured by HDK.
②	Printed Circuit	CEM-3、UL94V-0、t=1.6mm
③	Surface Mounted Parts	Surface Mounted Parts is Pb free.
④	Connector	S4B-PH-K-S(LF) 、2mm pitch Manufactured by JST
⑤	Thermistor	NCP15XV103E03RC Manufactured by Murata Manufacturing.

### 04. Absolute Maximum Ratings

(1) Voltage range : DC. 0~7(V)

(2) Temperature and Humidity Condition

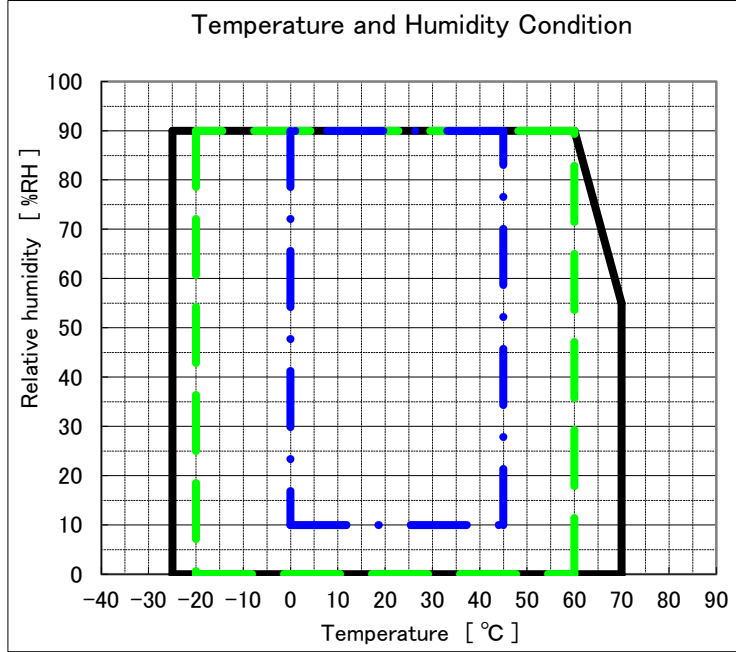

	① Storage Range
	② Operating Range
	③ Humidity detection Range

\* Do not allow condensation

### 05. Recommended Voltage Range

Power supply voltage range : DC. 5V±5%

### 06. Measuring Circuit

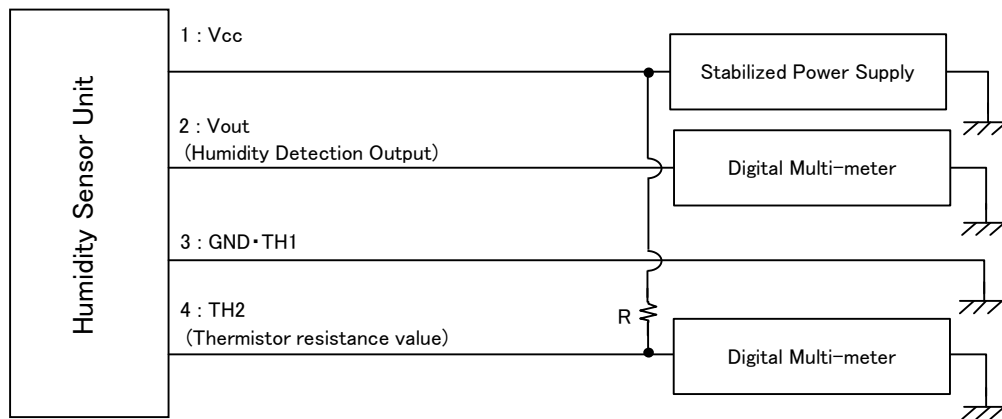

Model Name	Management No.	Page
HSU-08F9C1A-D	KRH2512079	6

### 07. Electrical Characteristics

T<sub>a</sub>=25°C, V<sub>cc</sub>=5.0V, unless otherwise noted.

Humidity detection output (V<sub>out</sub>) is measured by measurement circuit of item 06.

Item	Conditions	MIN.	TYP.	MAX.	Unit
Humidity Detection Output	T <sub>a</sub> =25°C, H=40%RH	0.963 (-5%RH)	1.069	1.162 (+5%RH)	V
	T <sub>a</sub> =25°C, H=60%RH	1.318 (-5%RH)	1.386	1.451 (+5%RH)	V
Consumption Current	I <sub>cc</sub> 20~90%RH	—	1.3	3.0	mA
Hysteresis Characteristics	30~90%RH	—	±1	—	%RH
Humidity Response Characteristics	30%RH↔90%RH (90% arrival) Air flow velocity 1.2cm/sec	—	3.5	—	min

Item	Conditions	Standard value	Unit
Thermistor Characteristics	Resistance value	25°C	10kΩ ±3%
	B Constant	25°C/50°C	3,900K±3%
	Rated Wattage	—	100

Model Name	Management No.	Page
HSU-08F9C1A-D	KRH2512079	7

## 08. Standard Reliability Test

	Test Item	Test Condition	Criteria
1	Drop Test	Drop the test piece naturally three times from height of 1m on to wooden board of 30mm thickness.	No abnormality in appearance and humidity detection output shall be in electric characteristics of item 07.
2	Heat Cycle	-25°C(1h) ⇄ 70°C(1h) 100cycles (Without dew condensation)	The change in humidity detection output in item 07 must be within ±5% RH of the initial value.
3	Exposure to High Temperature	Exposed to temp. of +70±1°C for 1000h.	
4	Exposure to Low Temperature	Exposed to temp. of -25±1°C for 1000 h.	
5	Exposure to High Humidity	Exposed to temp. of +40±5°C with 90±5%RH for 1000 h.	

### Caution

- (1) Measurement of humidity detection output is done after 15 minutes has passed with advantage way-type precision humidity producing device after temperature humidity setting.
- (2) Measurement of reliability test parts is done after they are left for more than 2 hours in normal temperature and normal humidity.

Model Name	Management No.	Page
HSU-08F9C1A-D	KRH2512079	8

### 09. Microcomputer connection and recommended circuit

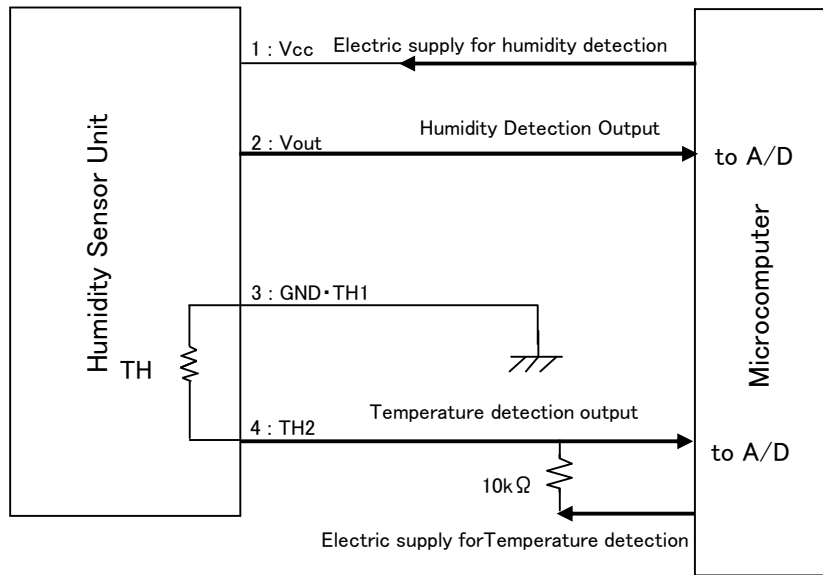

### 10. Lot Number

Stamp the lot number with black ink or laser at the position shown in the figure below.

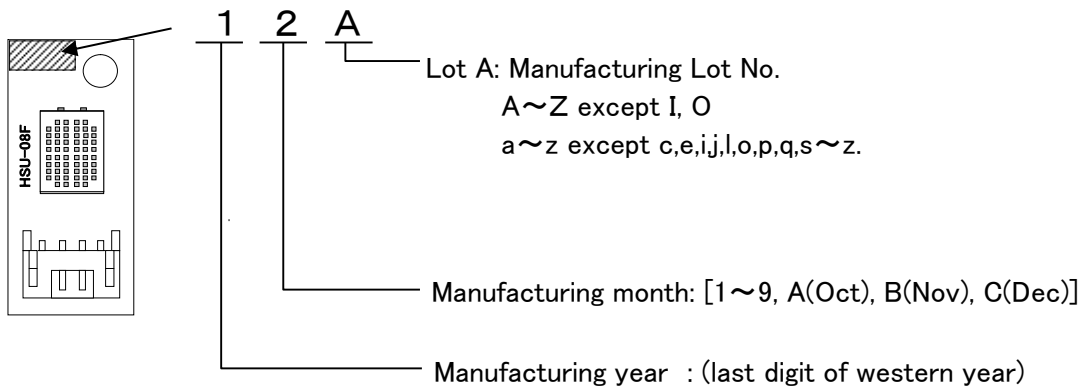

Model Name	Management No.	Page
HSU-08F9C1A-D	KRH2512079	9
<p><b>11. Notes for Use</b></p> <p>(1) Do not get the product wet in the water, and do not let it have dewdrops. Characteristics may change permanently.</p> <p>(2) Do not make foreign materials such as a solvent, oil and fat stick to the humidity sensor. It may stop fulfilling normal features.</p> <p>(3) This product is the electronic components with integrated circuit. Please take into consideration enough against static electricity.</p> <p>(4) This product is intended to be used for general electrical equipment. Please contact us in advance in case of the following application to be used; Extremely-high reliability demanding applications, such as medical equipment, safety device, aerospace instrument, nuclear energy control equipment, combustion control apparatus and so on, which failure and/or malfunction could do serious damage to human life, body, property and so on, directly or indirectly.</p>		
<b>HOKURIKU ELECTRIC INDUSTRY CO., LTD.</b>		

Model Name	Management No.	Page
HSU-08F9C1A-D	KRH2512079	10
<p><b>12. Others</b></p> <p>(1) The doubts of the specifications In case of any doubt in this specification, it should be resolved on mutual discussion between both parties.</p> <p>(2) In such cases as the industrial property In case that industrial property's dispute happens about our produced PCB and component We have delivered between you and a third party ,we try to solve on our own responsibility.</p> <p>(3) Existence of regulation by Export Trade Control Ordinance This PCB doesn't fall under the object of materials by COCOM.</p> <p>(4) Regulations on the use of class 1 ozone-depleting substances and specified bromine-based flame-retardant materials We never use the following materials in process of manufacturing this PCB and components. CFCs, CCl4, 1-1-1 trichloroethane, PBBOs, PBBs</p> <p>(5) Environment This product complies with the European RoHS Directive at the time of issuance of this delivery specification. In addition, it is based on "Hokuriku Electric Industry Co., Ltd. Green Procurement Guideline.</p> <p>(6) Producing district The production areas of this product are as follows. No.77 Zhongning Road. Jinnan Economic Development Area, Jinnan-Qu, Tianjin 300350, China Tianjin Hokuriku Electric Industry Co., Ltd.</p>		
<b>HOKURIKU ELECTRIC INDUSTRY CO., LTD.</b>		

### 13. Humidity detection output characteristic (reference data)

Measures in measurement circuit of item 06.  $V_{CC}=5.0V$

Output voltage [V]		Relative humidity (%RH)							
Temperature	10	20	30	40	50	60	70	80	90
5°C	0.260	0.494	0.836	1.073	1.245	1.379	1.498	1.621	1.752
25°C	0.106	0.519	0.838	1.069	1.244	1.386	1.513	1.637	1.769
45°C	0.170	0.609	0.885	1.084	1.243	1.381	1.520	1.650	1.770

