

# Specification

Force Sensor : HFD-20N-A02

## 1. Application

This specification shall apply to semiconductor piezo-resistive type (Bridge circuit) force sensor HFD-20N-A01.

## 2. Rating

### 2-1. Maximum Absolute Rating

Item	Rating			Unit	Remarks
	Min.	Typ.	Max.		
Supply Voltage	-	-	5.5	[V]	
Storage Temperature	-40	-	85	[°C]	
Operating Temperature	-20	-	60	[°C]	
Destructive Force	30	-	-	[N]	Static force durability
Lifespan	1000k	-	-	[Cycles]	10~20N 60Hz (Sine wave)
Reflow Temperature			250	[°C]	60sec or less at 230°C or more, 2 times Max.
			10	[sec]	

### 2-2. Rating (V<sub>cc</sub>=3V, T<sub>a</sub>=25°C)

Item	Rating			Unit	Remarks
	Min.	Typ.	Max.		
Operating Force Range	0	-	20	[N]	
Supply Voltage	-	3	-	[V]	Available at less than 5.5V ※1
Bridge Resistance	3.5	5	6.5	[kΩ]	
Offset Voltage	-10	-	10	[mV]	Output Voltage When 0[N]
Full Scale Span	210	300	390	[mV]	(Output 20[N]) -(Output 0[N]) ※2
Sensitivity	-	15	-	[mV/N]	
Linearity	-5	-	5	[%FS]	FS=Full Scale Span
Offset Temp. Characteristics	-5	-	5	[%FS]	Δfrom +25°C at -20 ~ +60°C
Sensitivity Temp. Characteristics	-0.1	-	0	[%FS/N/°C]	

※1 Sensor output becomes ratiometric to Supply voltage.

※2 OUTPUT Voltage = (+OUTPUT Voltage) - (-OUTPUT Voltage)

### 3. Outline Dimension and Terminal Assignment

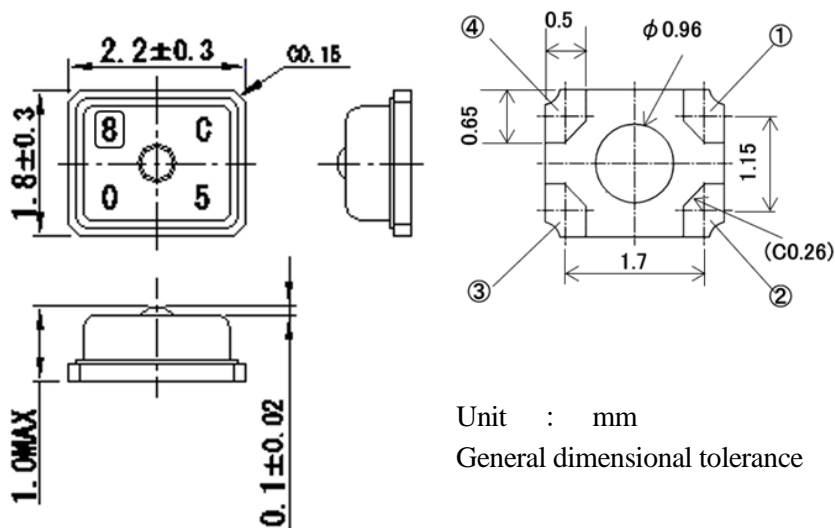

Unit : mm  
 General dimensional tolerance :  $\pm 0.1$ mm

#### Terminal assignment

(This product is symmetrical structure laterally and vertically.)

No	Name
①	Vcc
②	+OUTPUT
③	GND
④	-OUTPUT

#### Internal circuit

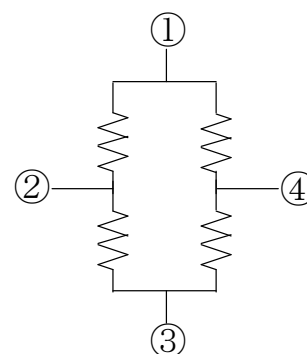

#### Soldering footprint (Recommended dimension)

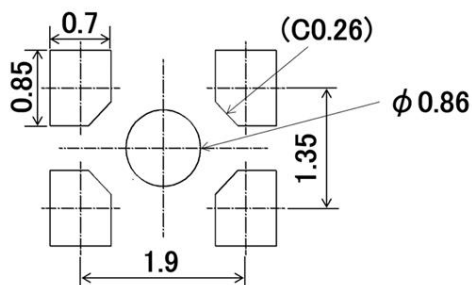

Unit : mm

\* This footprint does not guarantee soldering quality. Please check in advance at your company before use.

## 4. Marking

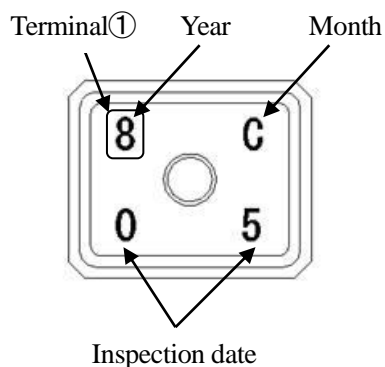

### <Lot No. designation>

Year	Last digit of manufactured year	
Month	Last digit of manufactured month 1~C ; ex) January ⇒ 1 October ⇒ A November ⇒ B December ⇒ C	
	Day	Characteristic inspection date

## 5. Reliability Test Specification

Item	Conditions	Testing time	Criteria
High temperature storage	85°C	250 hours	<ul style="list-style-type: none"> <li>• Change rate of offset voltage should be within <math>\pm 15\%</math>FS.</li> <li>• No abnormal appearance such as cracks, chips, deformation, etc. should exist.</li> </ul>
Low temperature storage	-40°C	250 hours	
High temperature, High humidity	85°C, 85%RH	250 hours	
Heat cycle	1 cycle for -40/85°C, 30 min each	100 cycles	
Repetitive Durability	10N $\leftrightarrow$ 20N, 16.7ms/cycle	1,000,000 times	

## 6. Packaging

### ■ Reel size

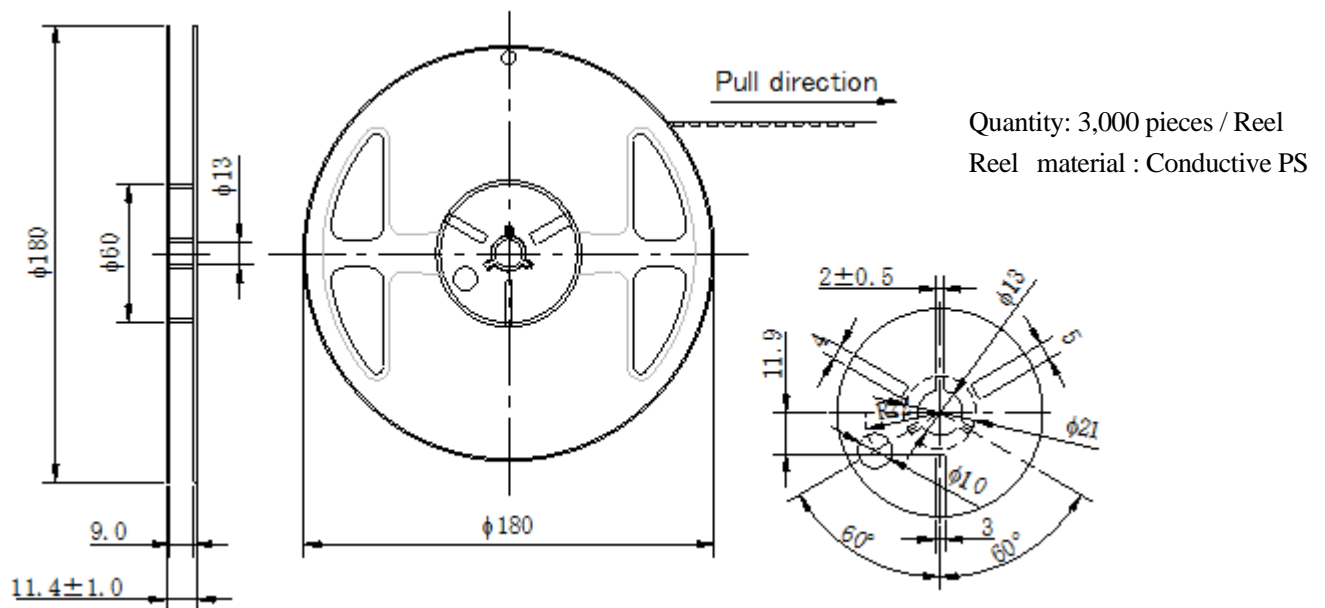

### ■ Carrier tape

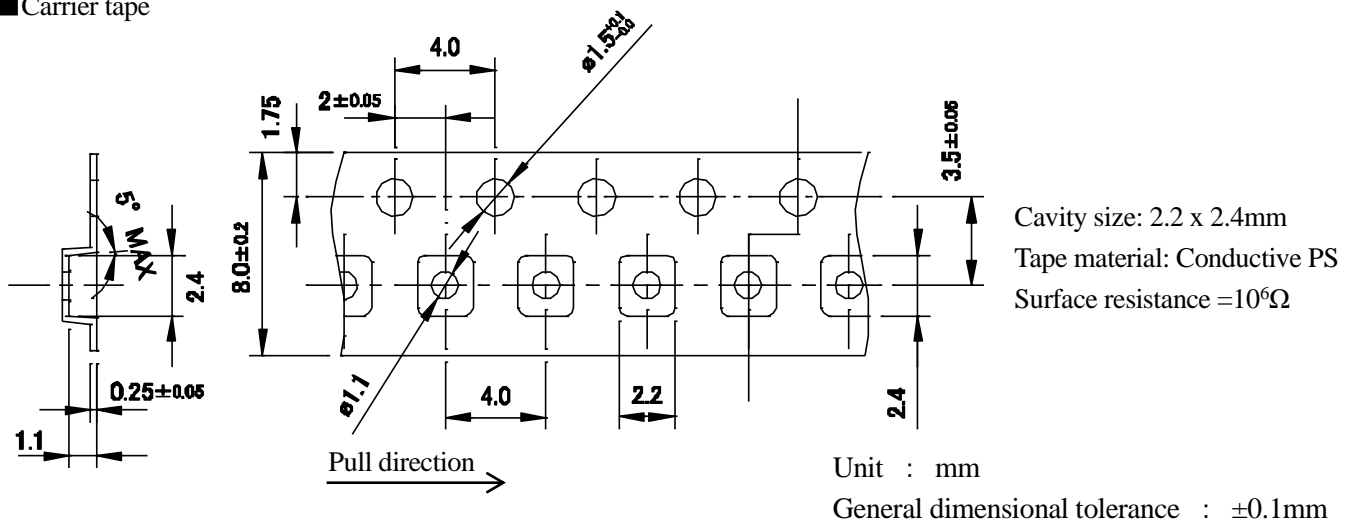

## 7. Storage Conditions

Product state	Storage Conditions	Retention period
Unopened packaging	Normal temperature and humidity (reference : temperature 10~40°C relative humidity 25~75%RH)	1year ※1
After opening the packaging	An atmosphere of dry air or dry nitrogen (reference : temperature 15~35°C relative humidity 40~60%RH)	6 Months ※1

※1 If the period expires, you do not need to do the baking, please check solderability of the terminal electrodes.

## 8. Notes

- This sensor is not constructed as drip-proof. In case that water drips or dew is condensed, the sensor may not perform as specified. Therefore, please consider structural aspect, when using on application.
- Please apply only reflow solder, and set up soldering conditions after checking at user side when soldering.
- Please do not wash (immersion or ultrasonic washing, etc.) after soldering sensor onto printed board.
- Please use hard material (made of metal, etc.) for force-applying part of your application as well, since force-receiving part (ball shape) of this sensor is made of hard metal (SUS material).  
If soft material is used in your application, it may lose accuracy.
- The force-receiving part of this sensor is susceptible to static electricity, since it is made of metal (SUS material).  
Therefore, please make sure to ground force-applying part of your application which contacts to the force-receiving part of this sensor, when using this sensor.
- Please do not intentionally rotate the force-receiving part(ball shape) of this sensor. Adhesion between the force-receiving part and the sensor element peels off, possibly losing the characteristics of this sensor.
- This sensor is not designed as radiation-proof. In case that excessive radiation was irradiated to the product, it may affect its performance.
- If this product touches corrosive gas (organic solvent, sulfurous acid gas, hydrogen sulfide gas, etc.), it may have a bad influence on performance.
- Please do not apply excessive shock to the force-receiving part (ball shape) of this sensor, otherwise sensor may be destroyed.
- RoHS compliance  
This sensor is Europe RoHS directive compliant product.  
And it conforms to the Green Procurement Rule of Hokuriku Electric Industry Co., Ltd.
- This sensor is intended to be used for general electrical equipment.  
For any other uses falling into the following category, please contact to our company in advance.  
Any uses in applications demanding extremely-high reliability such that failure or malfunction of medical equipment, safety device, aviation and space instrument, nuclear control equipment, combustion control apparatus, etc. is normally feared to cause serious damage to human life, body, property, etc., regardless direct or indirect.